

## **Features**

- Slim 2" (50.8) sightlines
- Tubular construction with shear block connections
- Split mullion unitized system for horizontal strip window
- Thermally improved framing
- Range of mullion sizes to suit design parameters
- Standard infill options 1/4" (6.4) and 1" (25.4), other infills available
- Integrated entrance framing
- Two color option
- Permanodic® anodized finishes option
- Painted finishes in standard and custom choices

## **Optional Features**

- Deep covers available
- Deep and heavy-weight mullions

For specific product applications,  
consult your Kawneer representative.

Laws and building and safety codes governing the design and use of Kawneer products, such as glazed entrance, window, and curtain wall products, vary widely. Kawneer does not control the selection of product configurations, operating hardware, or glazing materials, and assumes no responsibility therefor.

Kawneer reserves the right to change configuration without prior notice when deemed necessary for product improvement.  
© 2011, Kawneer Company, Inc.

**Architects** - Most extrusion and window types illustrated in this catalog are standard products for Kawneer. These concepts have been expanded and modified to afford you design freedom. Some miscellaneous details are non-standard and are intended to demonstrate how the system can be modified to expand design flexibility. Please contact your Kawneer representative for further assistance.

**PICTORIAL VIEW .....4**

**ELEVATION DETAILS WITHOUT BACKPAN .....5**

**ELEVATION DETAILS WITH BACKPAN .....6**

**ENTRANCE DETAILS .....7**

**CORNER DETAILS .....8**

**1602 WALL ELEVATION AND DETAILS .....9**

**COMPONENTS .....10**

**WIND LOAD/DEADLOAD CHARTS .....11-17**

**THERMAL CHARTS ..... 18-21**

Metric (SI) conversion figures are included throughout these details for reference. Numbers in parentheses ( ) are millimeters unless otherwise noted.

The following metric (SI ) units are found in these details:

- m – meter
- cm – centimeter
- mm – millimeter
- s – second
- Pa – pascal
- MPa – megapascal

Laws and building and safety codes governing the design and use of Kawneer products, such as glazed entrance, window, and curtain wall products, vary widely. Kawneer does not control the selection of product configurations, operating hardware, or glazing materials, and assumes no responsibility therefor.

Kawneer reserves the right to change configuration without prior notice when deemed necessary for product improvement.  
© 2011, Kawneer Company, Inc.

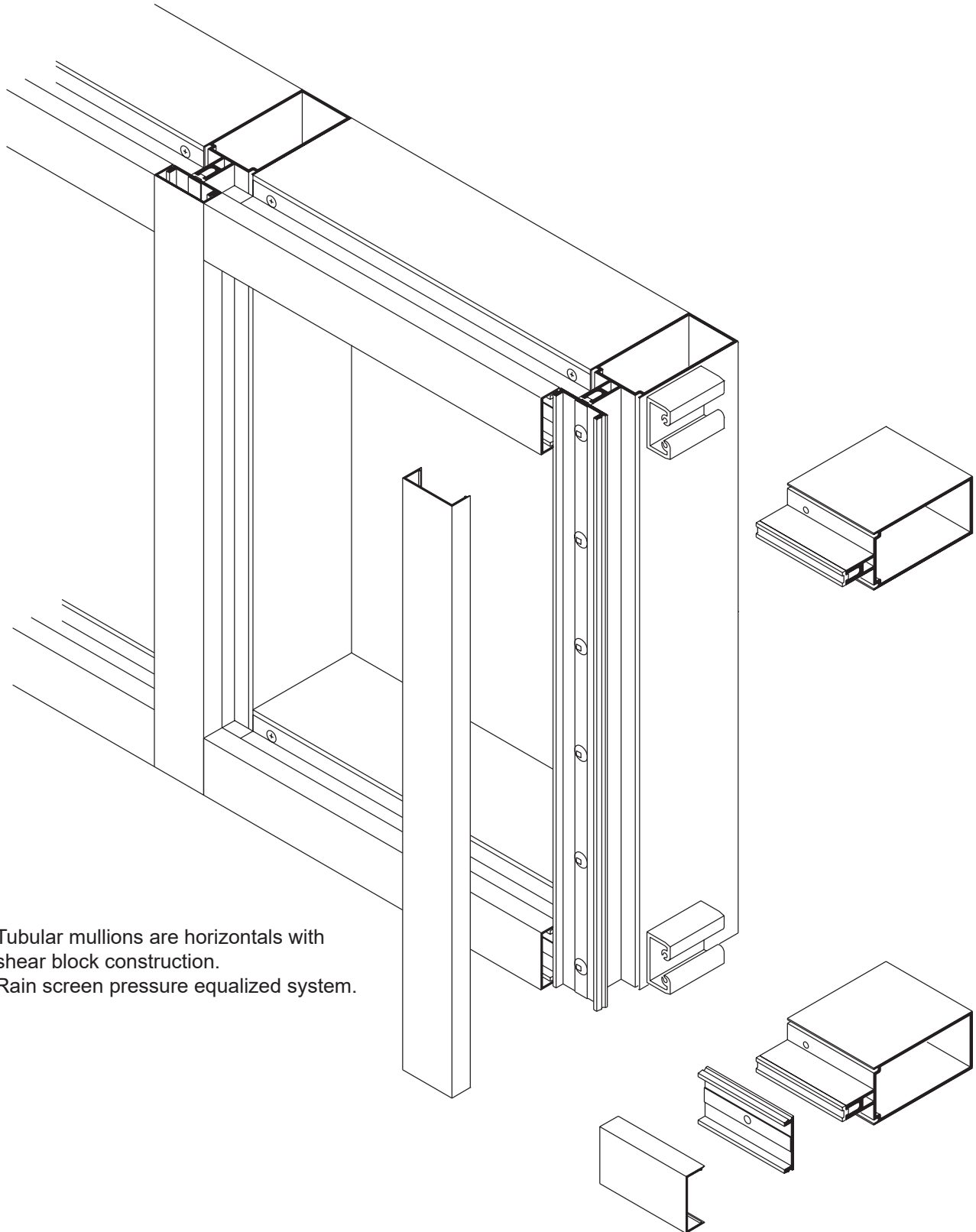

Tubular mullions are horizontals with shear block construction.  
Rain screen pressure equalized system.

Laws and building and safety codes governing the design and use of Kawneer products, such as glazed entrance, window, and curtain wall products, vary widely. Kawneer does not control the selection of product configurations, operating hardware, or glazing materials, and assumes no responsibility therefor.

Kawneer reserves the right to change configuration without prior notice when deemed necessary for product improvement.

© 2011, Kawneer Company, Inc.

Additional information and CAD details are available at [www.kawneer.com](http://www.kawneer.com)

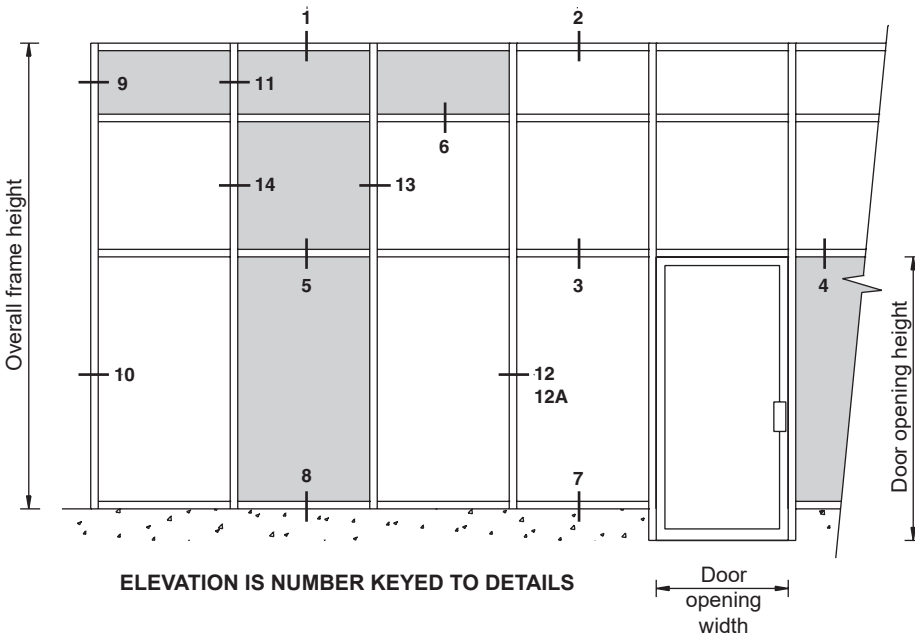

ELEVATION IS NUMBER KEYED TO DETAILS

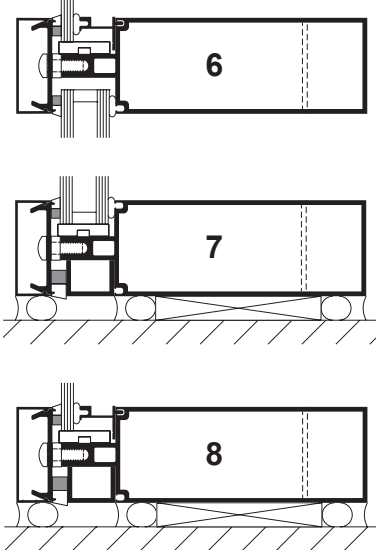
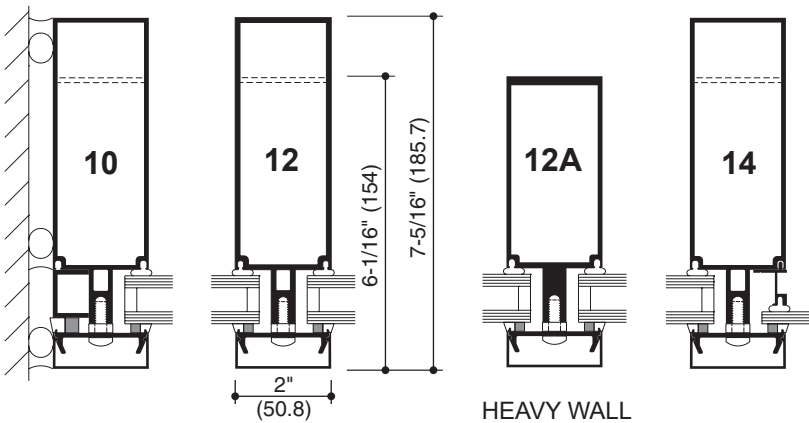
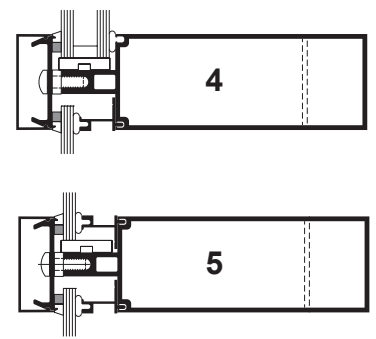
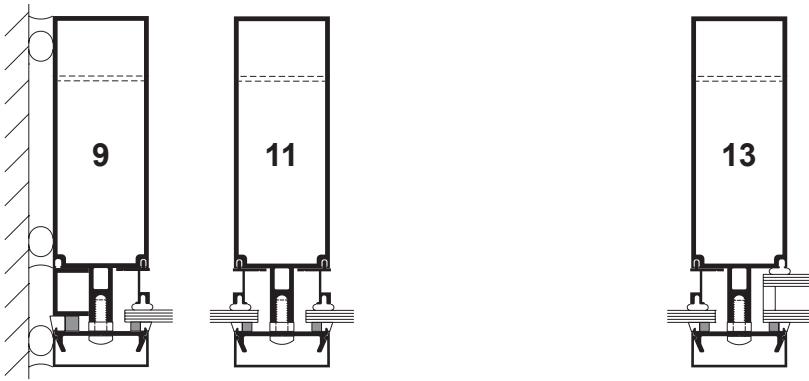
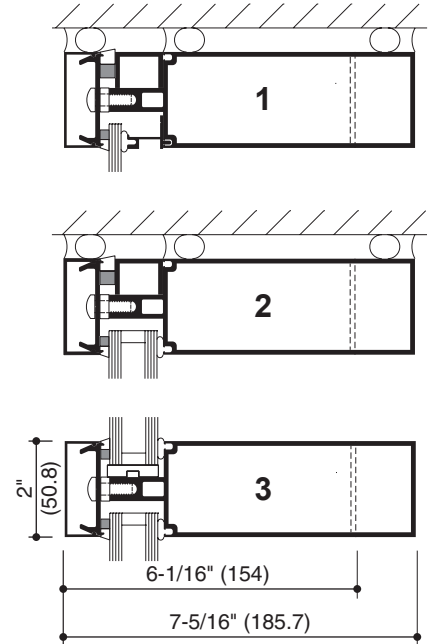

Laws and building and safety codes governing the design and use of Kawneer products, such as glazed entrance, window, and curtain wall products, vary widely. Kawneer does not control the selection of product configurations, operating hardware, or glazing materials, and assumes no responsibility therefor.

Kawneer reserves the right to change configuration without prior notice when deemed necessary for product improvement.  
© 2011, Kawneer Company, Inc.

Additional information and CAD details are available at [www.kawneer.com](http://www.kawneer.com)

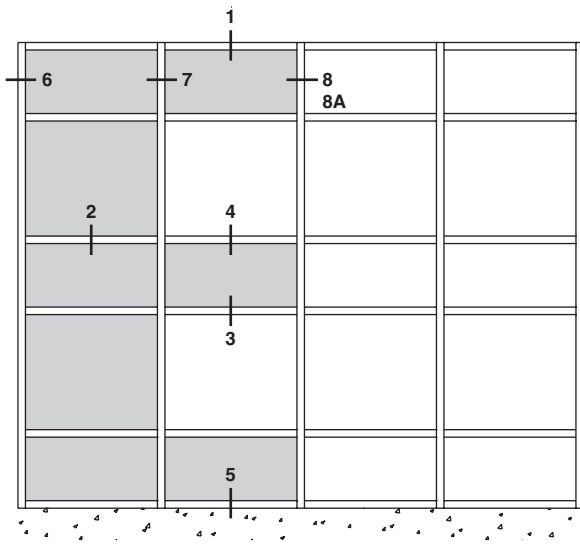

ELEVATION IS NUMBER KEYED TO DETAILS

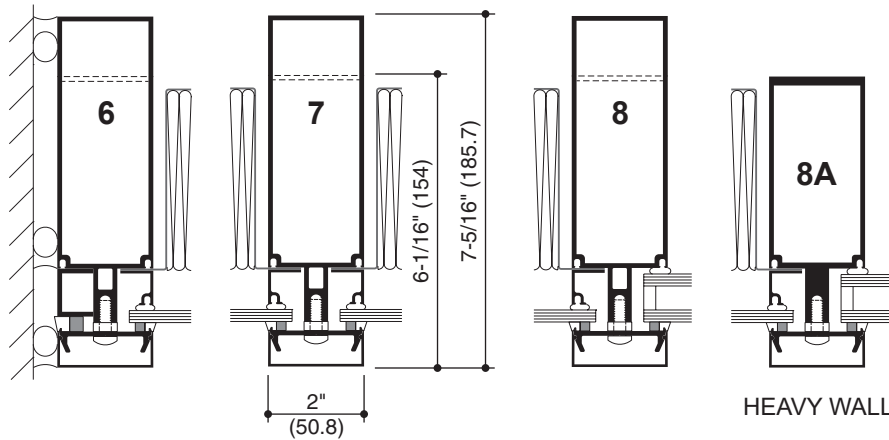
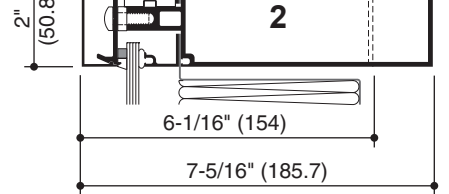
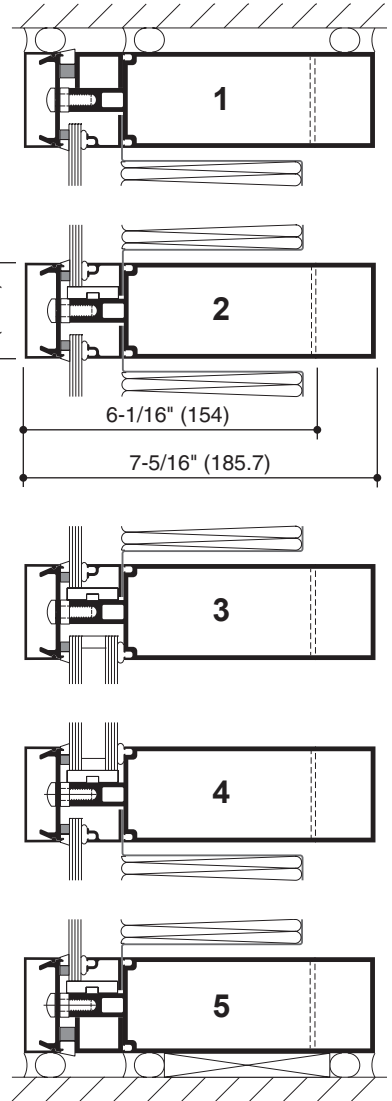

Laws and building and safety codes governing the design and use of Kawneer products, such as glazed entrance, window, and curtain wall products, vary widely. Kawneer does not control the selection of product configurations, operating hardware, or glazing materials, and assumes no responsibility therefor.

Kawneer reserves the right to change configuration without prior notice when deemed necessary for product improvement.  
© 2011, Kawneer Company, Inc.

Additional information and CAD details are available at [www.kawneer.com](http://www.kawneer.com)

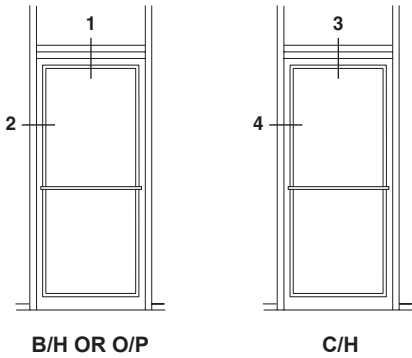

ELEVATION IS NUMBER KEYED TO DETAILS

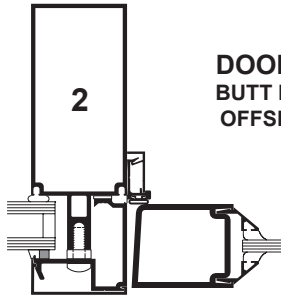

DOOR JAMB  
BUTT HUNG OR  
OFFSET PIVOT

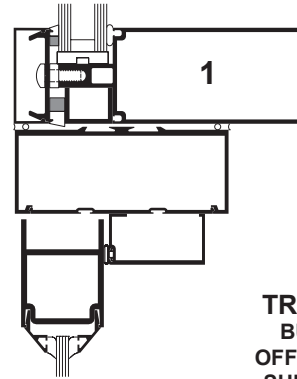

TRANSOM BAR  
BUTT HUNG OR  
OFFSET PIVOT WITH  
SURFACE CLOSER  
OR FLOOR CLOSER

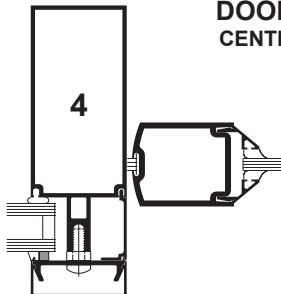

DOOR JAMB  
CENTER HUNG

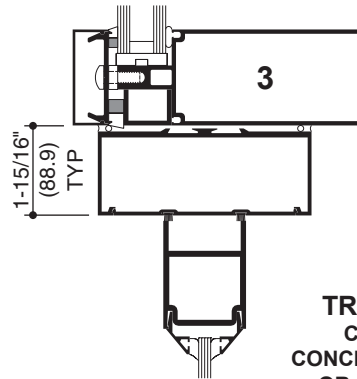

TRANSOM BAR  
CENTER HUNG  
CONCEALED OVERHEAD  
OR FLOOR CLOSER

Laws and building and safety codes governing the design and use of Kawneer products, such as glazed entrance, window, and curtain wall products, vary widely. Kawneer does not control the selection of product configurations, operating hardware, or glazing materials, and assumes no responsibility therefor.

Kawneer reserves the right to change configuration without prior notice when deemed necessary for product improvement.  
© 2011, Kawneer Company, Inc.

Additional information and CAD details are available at [www.kawneer.com](http://www.kawneer.com)

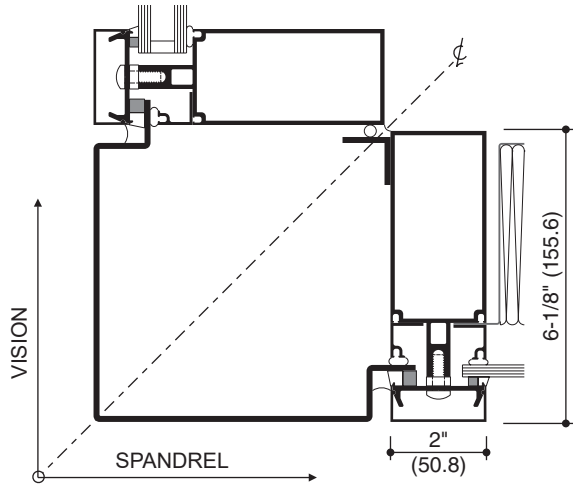

**90° OUTSIDE CORNER**

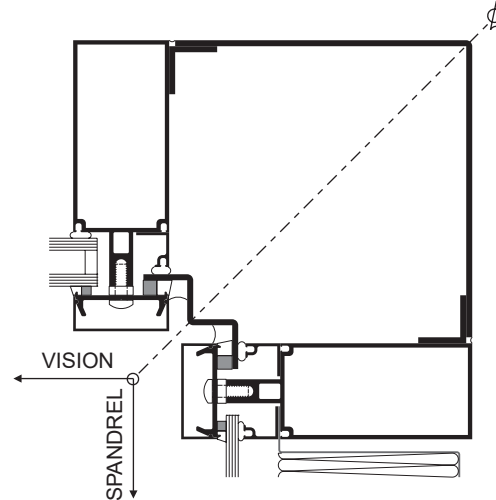

**90° INSIDE CORNER**

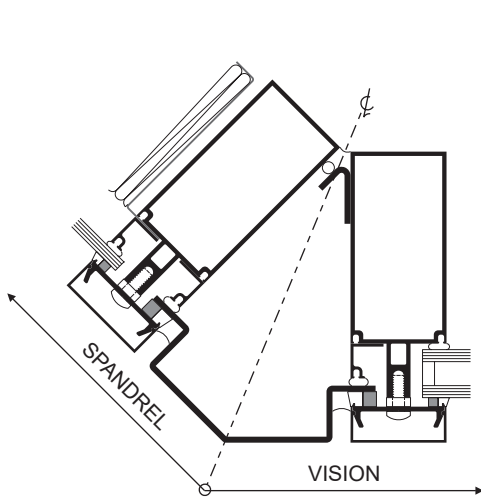

**135° OUTSIDE CORNER**

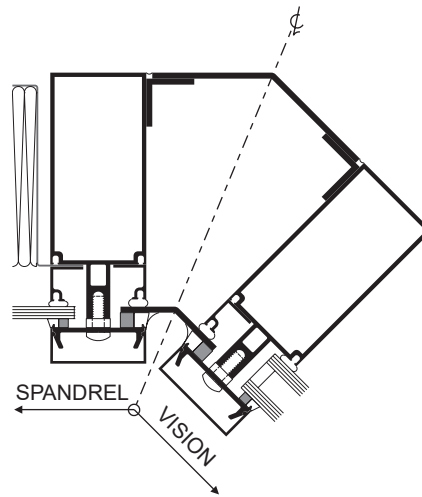

**135° INSIDE CORNER**

Laws and building and safety codes governing the design and use of Kawneer products, such as glazed entrance, window, and curtain wall products, vary widely. Kawneer does not control the selection of product configurations, operating hardware, or glazing materials, and assumes no responsibility therefor.

Kawneer reserves the right to change configuration without prior notice when deemed necessary for product improvement.  
© 2011, Kawneer Company, Inc.



Additional information and CAD details are available at [www.kawneer.com](http://www.kawneer.com)

**TYPE A**

**HORIZONTAL STRIP WINDOW**

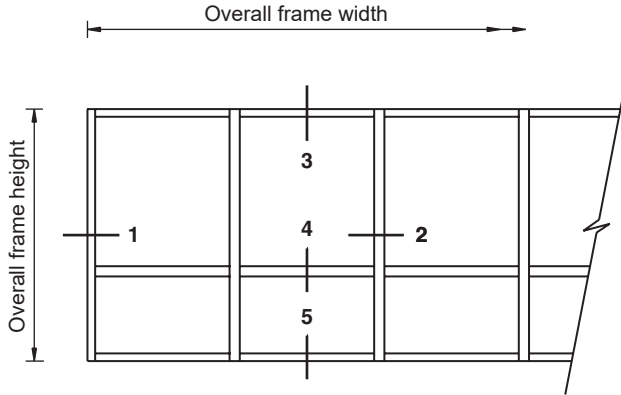

ELEVATION IS NUMBER KEYED TO DETAILS

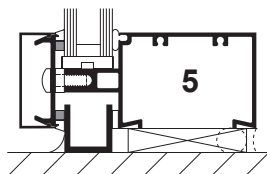
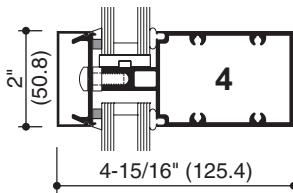
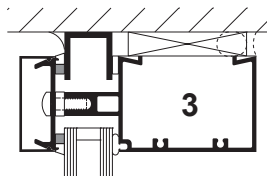
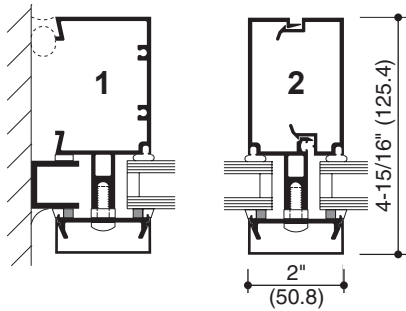

**TYPE B**

**PUNCHED OPENING WINDOW**

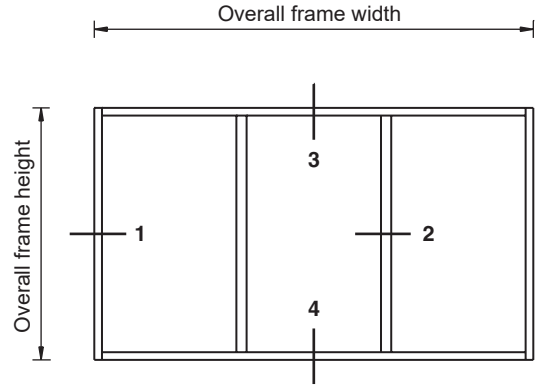

ELEVATION IS NUMBER KEYED TO DETAILS

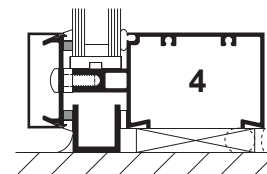
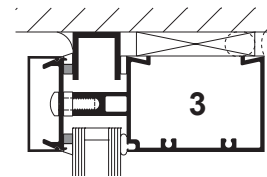
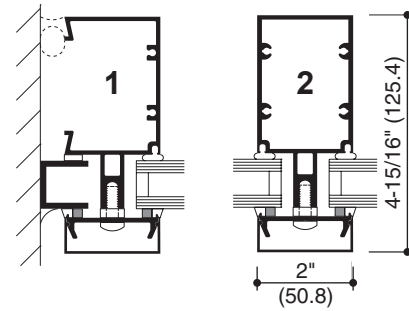

**NOTE:** 1602 WINDOW CAN ALSO BE FABRICATED AS A STICK SYSTEM.

Laws and building and safety codes governing the design and use of Kawneer products, such as glazed entrance, window, and curtain wall products, vary widely. Kawneer does not control the selection of product configurations, operating hardware, or glazing materials, and assumes no responsibility therefor.

Kawneer reserves the right to change configuration without prior notice when deemed necessary for product improvement.  
© 2011, Kawneer Company, Inc.

Additional information and CAD details are available at [www.kawneer.com](http://www.kawneer.com)

**WALL MULLIONS**  
(VERTICAL AND HORIZONTAL)

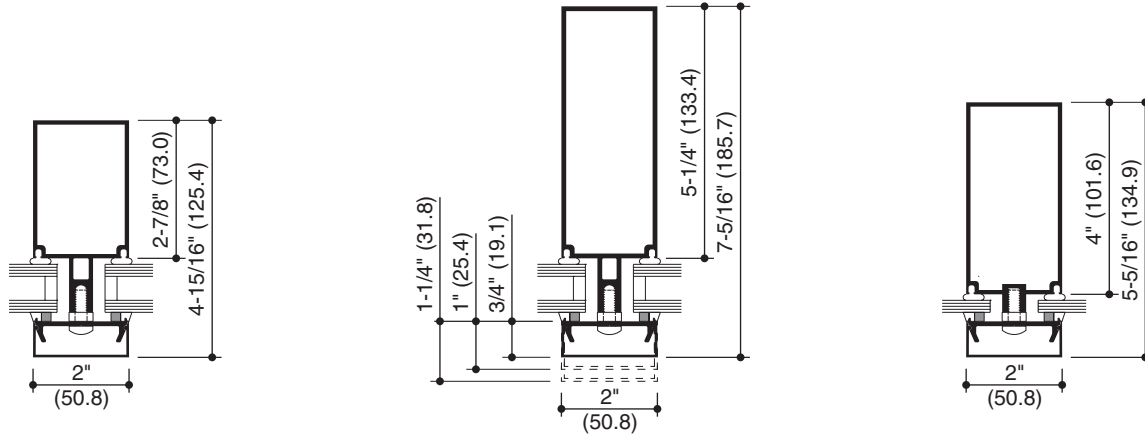

**OPTIONAL COVERS**

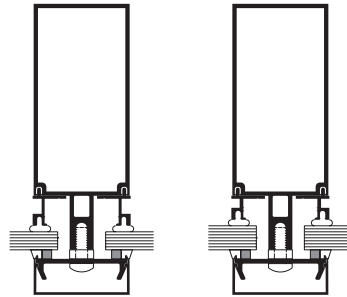

**WITHOUT BACKPAN ADAPTORS**

Laws and building and safety codes governing the design and use of Kawneer products, such as glazed entrance, window, and curtain wall products, vary widely. Kawneer does not control the selection of product configurations, operating hardware, or glazing materials, and assumes no responsibility therefor.

Kawneer reserves the right to change configuration without prior notice when deemed necessary for product improvement.  
© 2011, Kawneer Company, Inc.

## WIND LOAD CHARTS

Mullions are designed for deflection limitations in accordance with AAMA TIR-A11 of L/175 up to 13' 6" and L/240 +1/4" above 13' 6". These curves are for mullions WITH HORIZONTALS and are based on engineering calculations for stress and deflection. Allowable wind load stress for ALUMINUM 15,152 psi (104 MPa), STEEL 30,000 psi (207 MPa). Charted curves, in all cases are for the limiting value. Wind load charts contained herein are based upon nominal wind load utilized in allowable stress design. A conversion from Load Resistance Factor Design (LRFD) is provided. To convert ultimate wind loads to nominal loads, multiply ultimate wind loads by a factor of 0.6 per ASCE/SEI 7. A 4/3 increase in allowable stress has not been used to develop these curves. For special situations not covered by these curves, contact your Kawneer representative for additional information.

## DEADLOAD CHARTS

Horizontal or deadload limitations are based upon 1/8" (3.2), maximum allowable deflection at the center of an intermediate horizontal member. The accompanying charts are calculated for 1" (25.4) thick insulating glass or 1/4" (6.4) thick glass supported on two setting blocks placed at the loading points shown.

Laws and building and safety codes governing the design and use of Kawneer products, such as glazed entrance, window, and curtain wall products, vary widely. Kawneer does not control the selection of product configurations, operating hardware, or glazing materials, and assumes no responsibility therefor.

Kawneer reserves the right to change configuration without prior notice when deemed necessary for product improvement.  
© 2011, Kawneer Company, Inc.

	Allowable Stress Design Load	LRFD Ultimate Design Load
A =	20 PSF (960)	33 PSF (1580)
B =	30 PSF (1440)	50 PSF (2400)
C =	40 PSF (1920)	67 PSF (3200)
D =	50 PSF (2400)	83 PSF (4000)
E =	60 PSF (2880)	100 PSF (4790)

## SINGLE SPAN

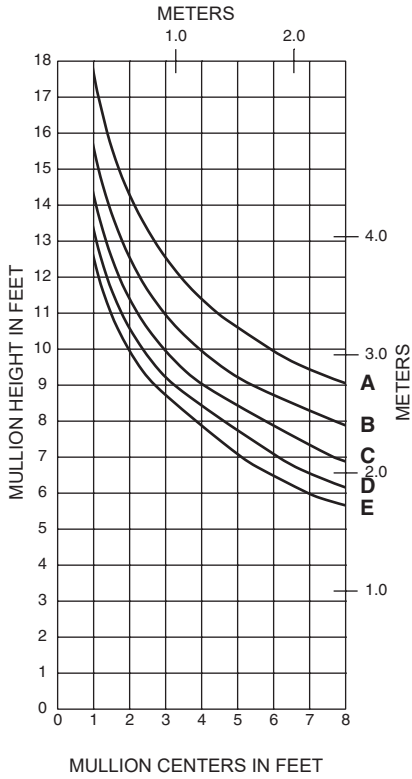

820301

$I = 3.883(161.62 \times 10^4)$   
 $S = 1.488(24.38 \times 10^3)$

## TWIN SPAN

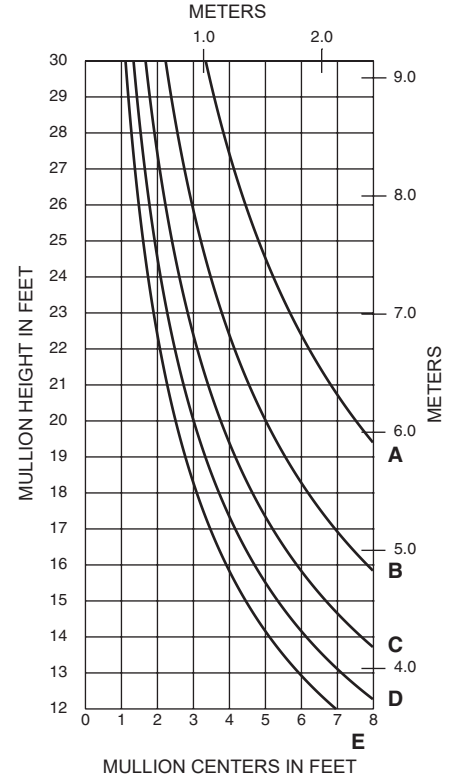

## SINGLE SPAN

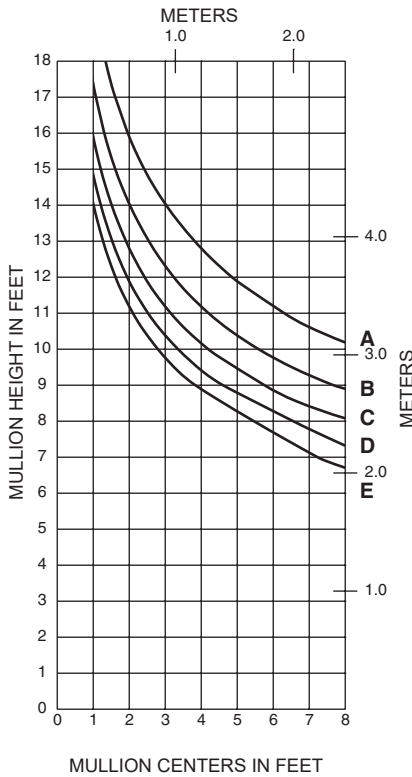

820302

$I = 5.507(229.22 \times 10^4)$   
 $S = 2.105(34.49 \times 10^3)$

## TWIN SPAN

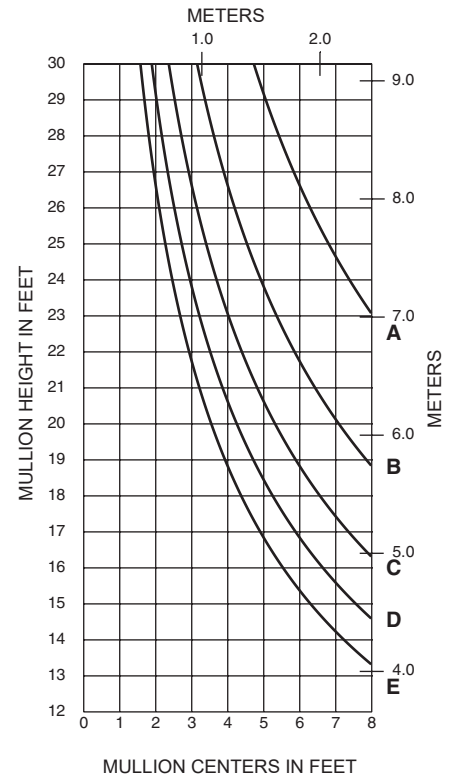

Laws and building and safety codes governing the design and use of Kawneer products, such as glazed entrance, window, and curtain wall products, vary widely. Kawneer does not control the selection of product configurations, operating hardware, or glazing materials, and assumes no responsibility therefor.

Kawneer reserves the right to change configuration without prior notice when deemed necessary for product improvement.  
 © 2011, Kawneer Company, Inc.

Laws and building and safety codes governing the design and use of Kawneer products, such as glazed entrance, window, and curtain wall products, vary widely. Kawneer does not control the selection of product configurations, operating hardware, or glazing materials, and assumes no responsibility therefor.

Kawneer reserves the right to change configuration without prior notice when deemed necessary for product improvement.  
© 2011, Kawneer Company, Inc.

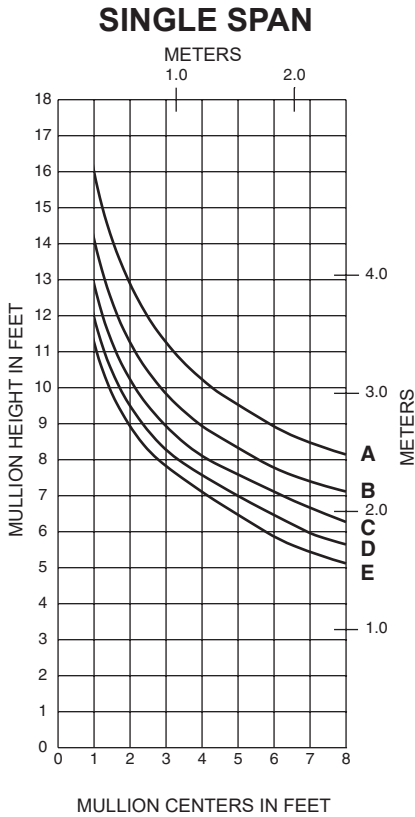

	Allowable Stress Design Load	LRFD Ultimate Design Load
A =	20 PSF (960)	33 PSF (1580)
B =	30 PSF (1440)	50 PSF (2400)
C =	40 PSF (1920)	67 PSF (3200)
D =	50 PSF (2400)	83 PSF (4000)
E =	60 PSF (2880)	100 PSF (4790)

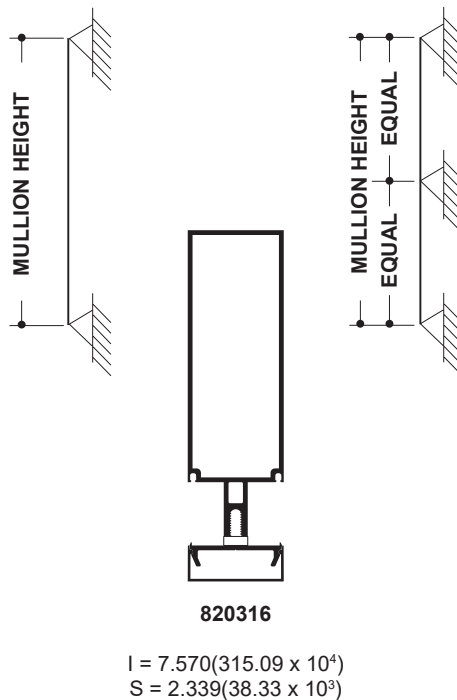
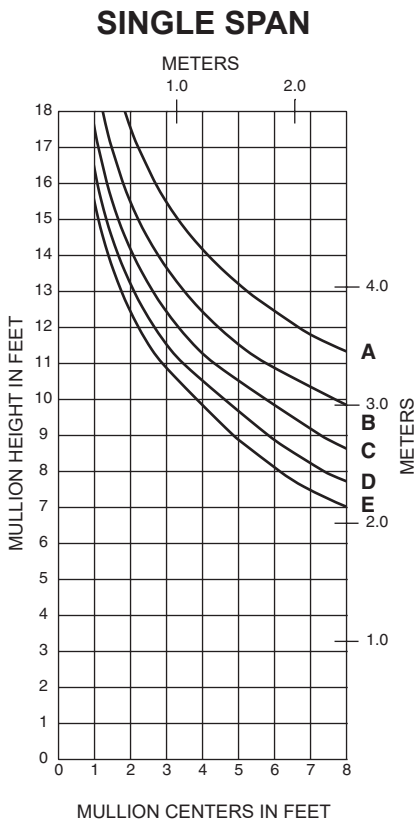
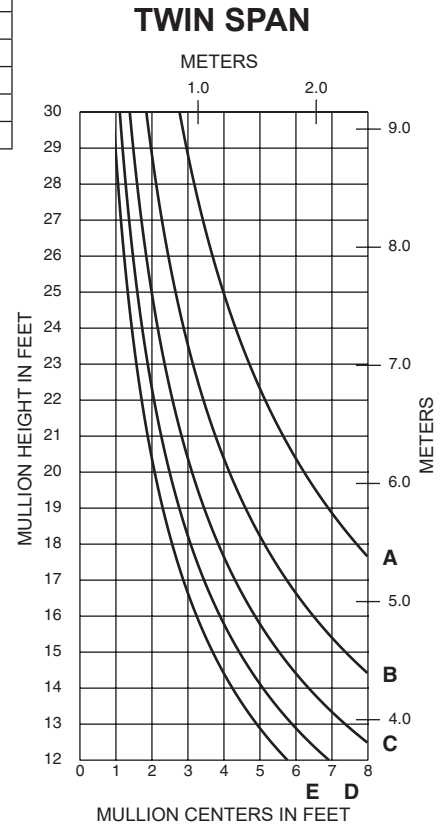

## SINGLE SPAN

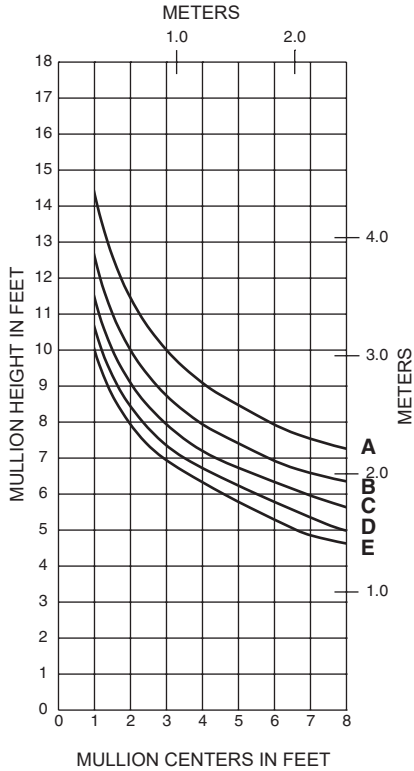

**820317**

$I = 1.970(82.00 \times 10^4)$   
 $S = 0.982(16.09 \times 10^3)$

## SINGLE SPAN

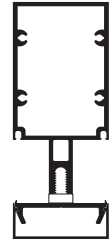
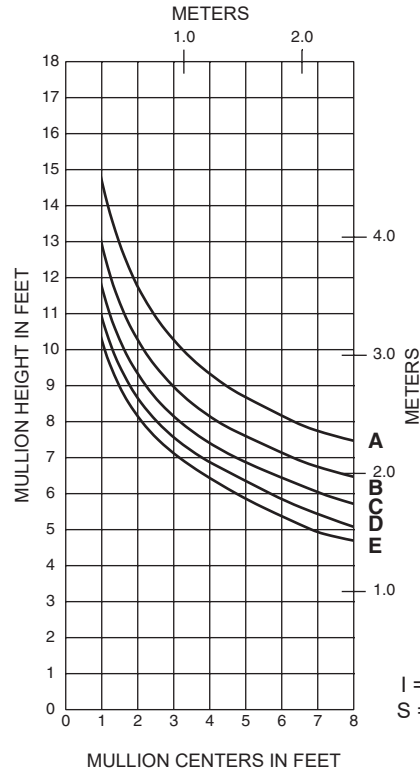

**821852**

$I = 2.131(88.70 \times 10^4)$   
 $S = 1.014(16.61 \times 10^3)$

## SINGLE SPAN

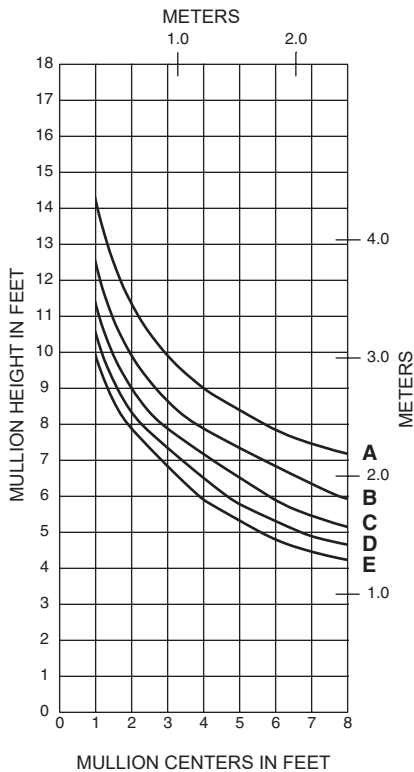

**820853 & 821854**

$I = 1.916(79.75 \times 10^4)$   
 $S = 0.830(13.60 \times 10^3)$

	Allowable Stress Design Load	LRFD Ultimate Design Load
<b>A =</b>	<b>20 PSF (960)</b>	<b>33 PSF (1580)</b>
<b>B =</b>	<b>30 PSF (1440)</b>	<b>50 PSF (2400)</b>
<b>C =</b>	<b>40 PSF (1920)</b>	<b>67 PSF (3200)</b>
<b>D =</b>	<b>50 PSF (2400)</b>	<b>83 PSF (4000)</b>
<b>E =</b>	<b>60 PSF (2880)</b>	<b>100 PSF (4790)</b>

Laws and building and safety codes governing the design and use of Kawneer products, such as glazed entrance, window, and curtain wall products, vary widely. Kawneer does not control the selection of product configurations, operating hardware, or glazing materials, and assumes no responsibility therefor.

Kawneer reserves the right to change configuration without prior notice when deemed necessary for product improvement.  
 © 2011, Kawneer Company, Inc.

A - 1/8 POINT LOADING  
 B - 1/4 POINT LOADING

1/4" INFILL

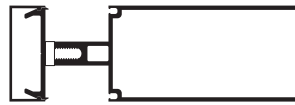
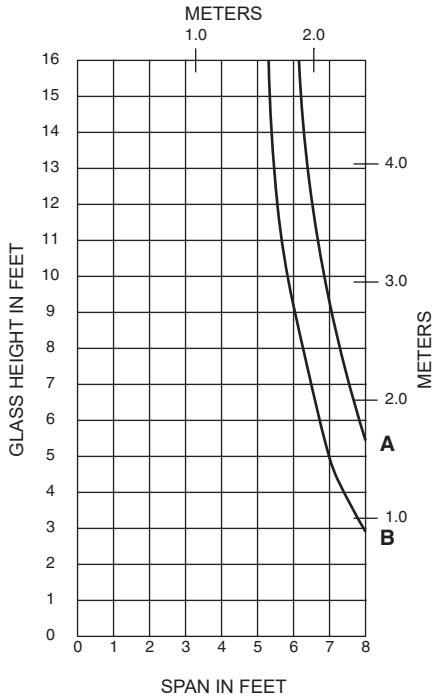

820301

$I = 0.766(31.88 \times 10^4)$   
 $S = 0.766(12.55 \times 10^3)$

1" INFILL

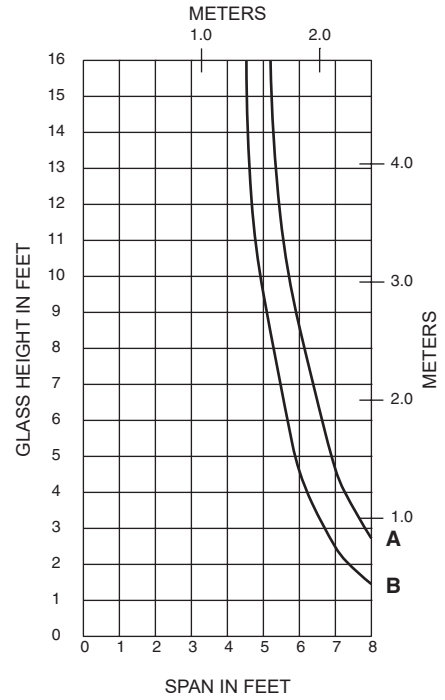

1/4" INFILL

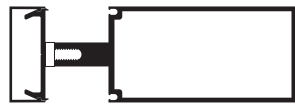
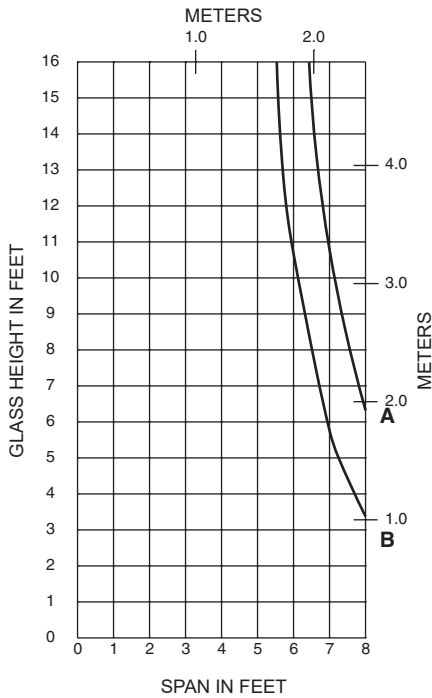

820302

$I = 0.890(37.04 \times 10^4)$   
 $S = 0.890(14.58 \times 10^3)$

1" INFILL

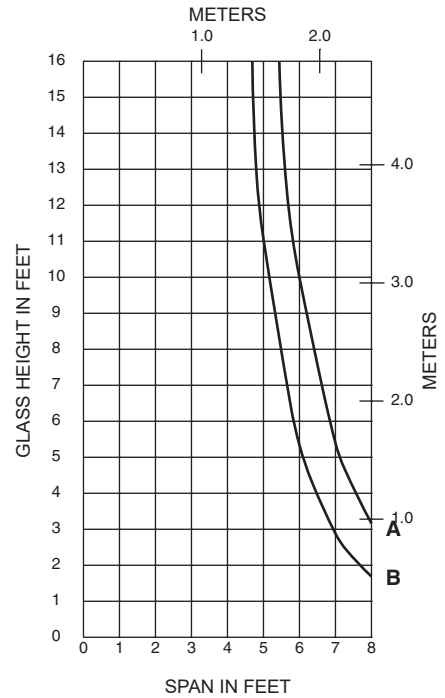

Laws and building and safety codes governing the design and use of Kawneer products, such as glazed entrance, window, and curtain wall products, vary widely. Kawneer does not control the selection of product configurations, operating hardware, or glazing materials, and assumes no responsibility therefor.

Kawneer reserves the right to change configuration without prior notice when deemed necessary for product improvement.  
 © 2011, Kawneer Company, Inc.

A - 1/8 POINT LOADING  
 B - 1/4 POINT LOADING

## 1/4" INFILL

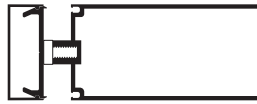
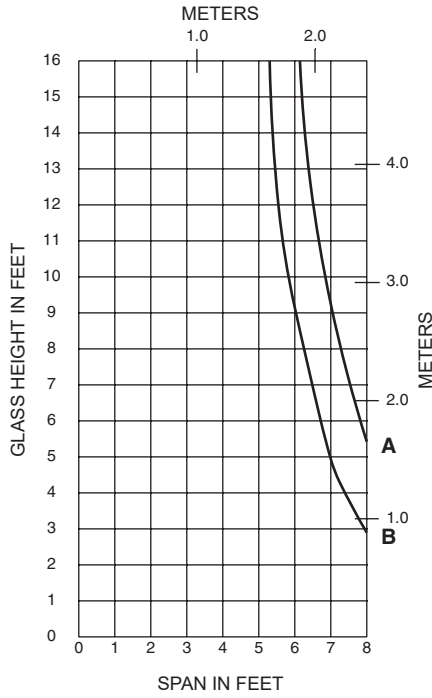

**820303**

$I = 0.763(31.76 \times 10^4)$   
 $S = 0.763(12.50 \times 10^3)$

## 1/4" INFILL

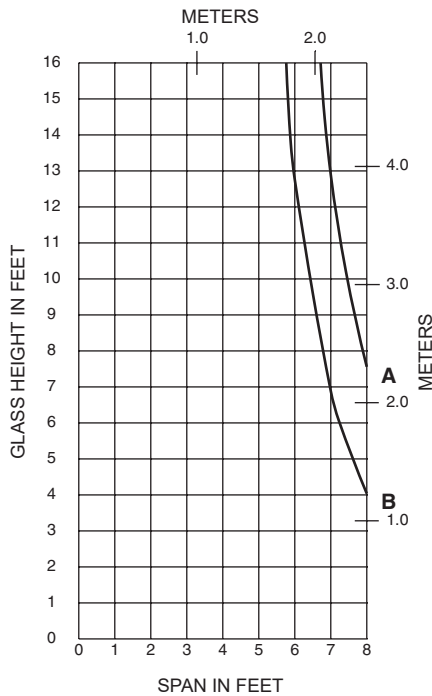

**820316**

$I = 1.064(44.29 \times 10^4)$   
 $S = 1.064(17.44 \times 10^3)$

## 1" INFILL

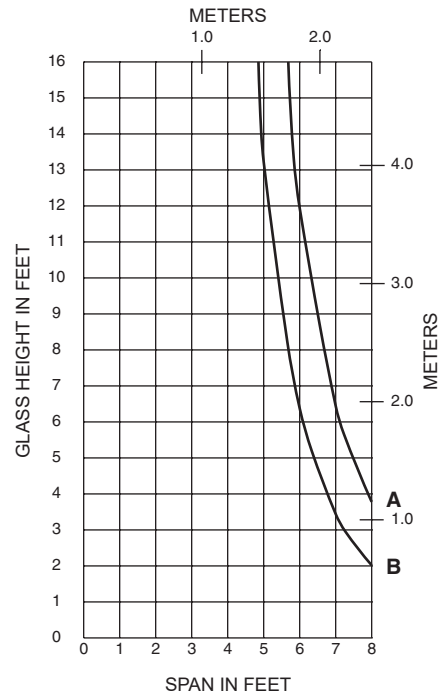

Laws and building and safety codes governing the design and use of Kawneer products, such as glazed entrance, window, and curtain wall products, vary widely. Kawneer does not control the selection of product configurations, operating hardware, or glazing materials, and assumes no responsibility therefor.

Kawneer reserves the right to change configuration without prior notice when deemed necessary for product improvement.  
 © 2011, Kawneer Company, Inc.



A - 1/8 POINT LOADING  
 B - 1/4 POINT LOADING

1/4" INFILL

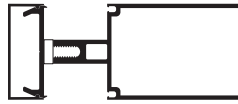
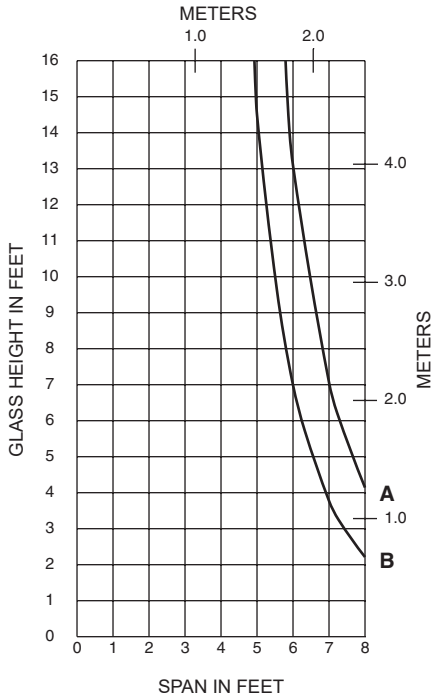

820317

$I = 0.583(24.27 \times 10^4)$   
 $S = 0.583(9.55 \times 10^3)$

1" INFILL

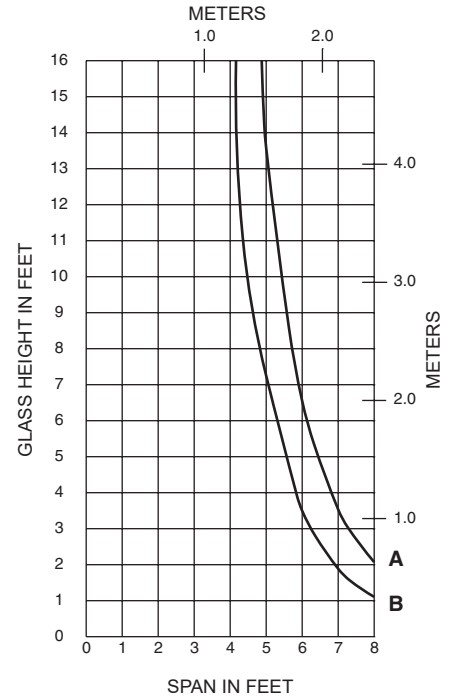

1/4" INFILL

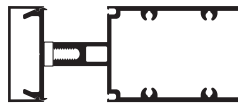
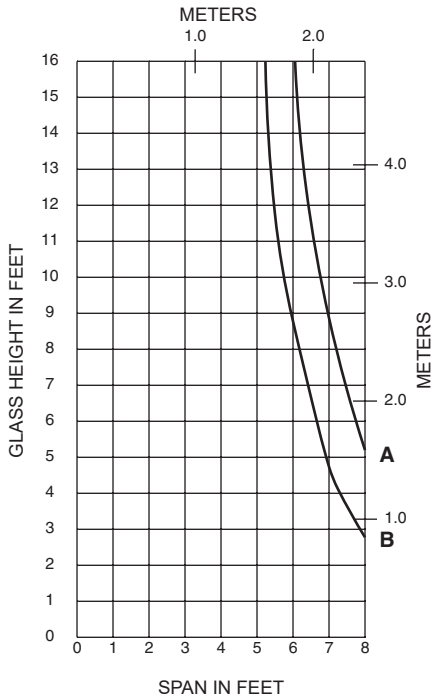

821852

$I = 0.732(30.47 \times 10^4)$   
 $S = 0.732(12.00 \times 10^3)$

1" INFILL

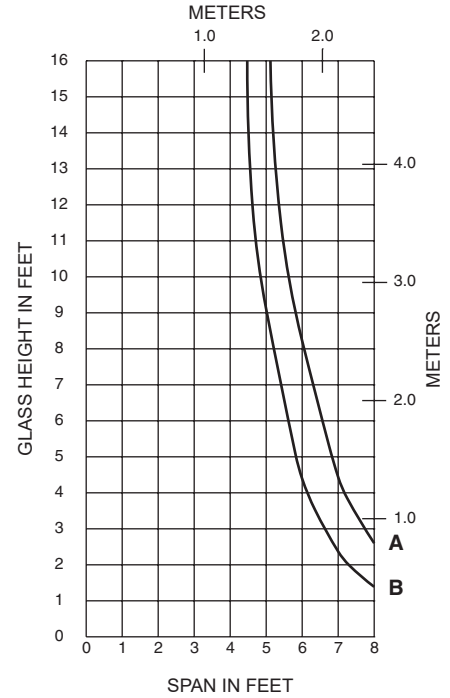

Laws and building and safety codes governing the design and use of Kawneer products, such as glazed entrance, window, and curtain wall products, vary widely. Kawneer does not control the selection of product configurations, operating hardware, or glazing materials, and assumes no responsibility therefor.

Kawneer reserves the right to change configuration without prior notice when deemed necessary for product improvement.  
 © 2011, Kawneer Company, Inc.

**Generic Project Specific U-factor Example Calculation**  
**(Percent of Glass will vary on specific products depending on sitelines)**  
 (Based on single bay of Curtain Wall/Window Wall)

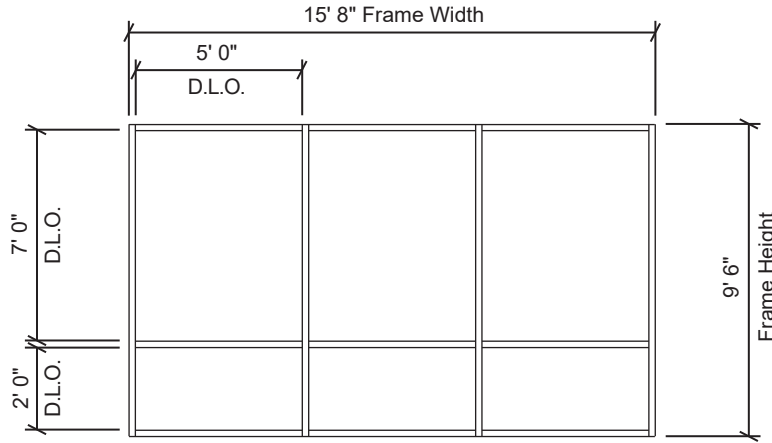

Example Glass U-Factor = 0.42 Btu/hr • ft<sup>2</sup> • °F

Total Daylight Opening = 3(5' x 7') + 3(5' x 2') = 135 ft<sup>2</sup>

Total Projected Area = 15' 8" x 9' 6" = 148.83 ft<sup>2</sup>

Percent of Glass = (Total Daylight Opening ÷ Total Projected Area)100  
 = (135 ÷ 148.83)100 = 91%

**System U-Factor vs Percent of Glass Area**

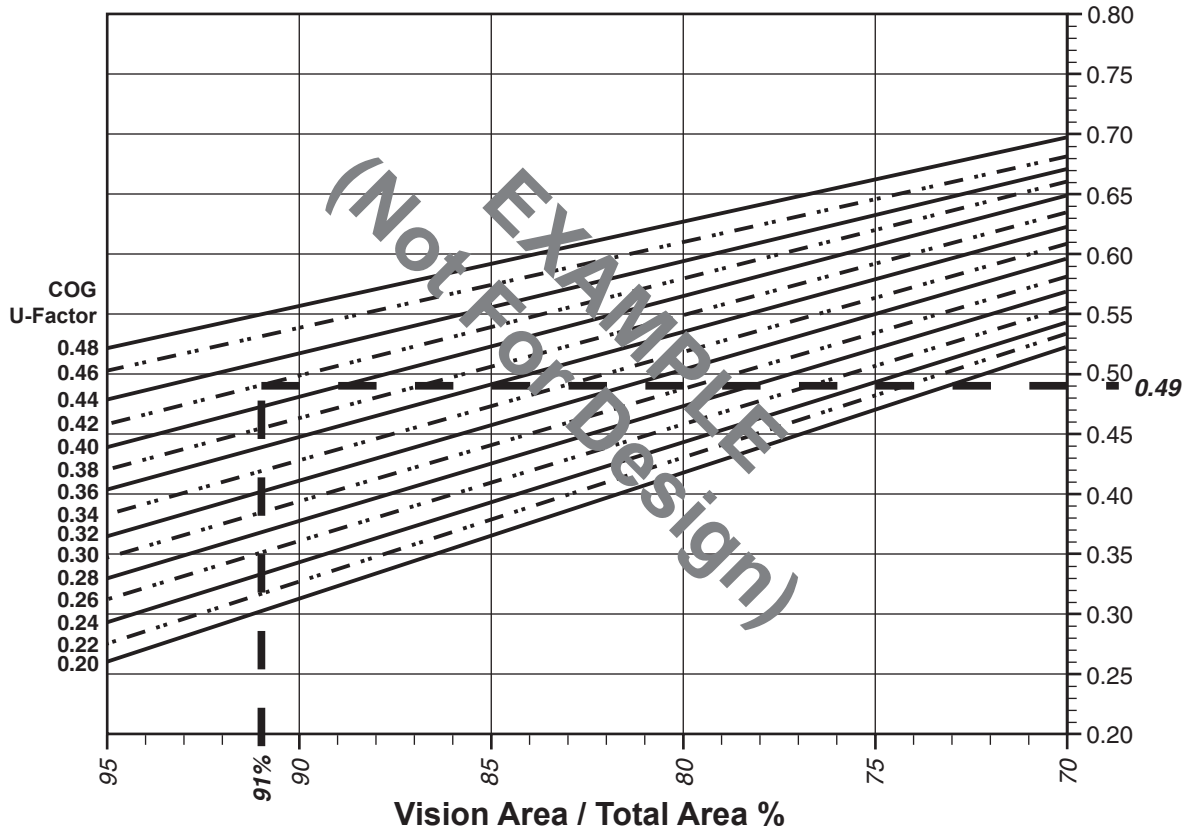

Based on 91% glass and center of glass U-Factor of 0.42  
 System U-Factor is equal to 0.49 Btu/hr • ft<sup>2</sup> • °F

Laws and building and safety codes governing the design and use of Kawneer products, such as glazed entrance, window, and curtain wall products, vary widely. Kawneer does not control the selection of product configurations, operating hardware, or glazing materials, and assumes no responsibility therefor.

Kawneer reserves the right to change configuration without prior notice when deemed necessary for product improvement.  
 © 2011, Kawneer Company, Inc.

**Note:**

Values in parentheses are metric.

COG = Center of Glass.

Charts are generated per AAMA 507

**System U-Factor vs Percent of Glass Area**

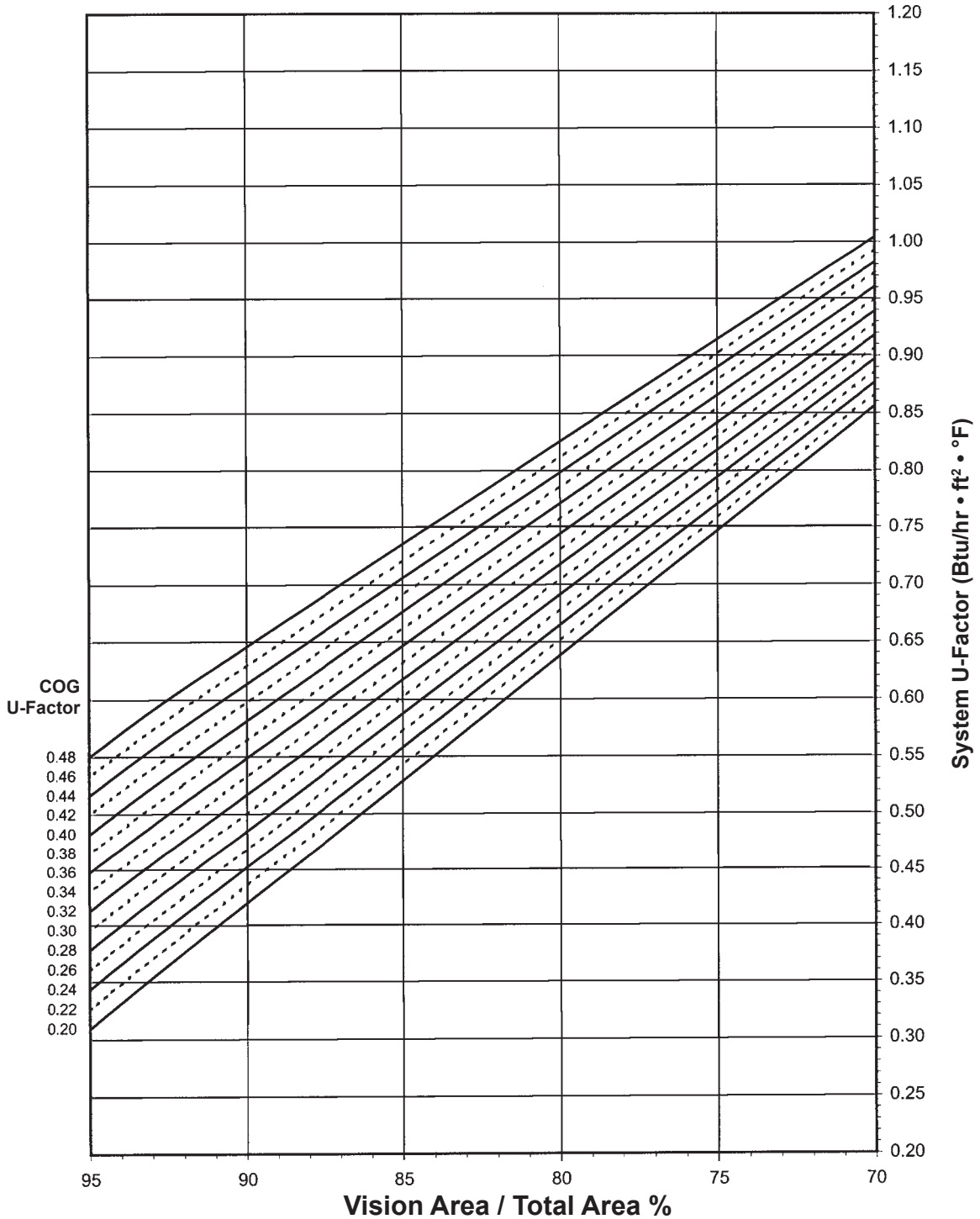

**Notes for System U-Factor, SHGC and VT charts:**

For glass values that are not listed, linear interpolation is permitted.

Glass properties are based on center of glass values and are obtained from your glass supplier.

Laws and building and safety codes governing the design and use of Kawneer products, such as glazed entrance, window, and curtain wall products, vary widely. Kawneer does not control the selection of product configurations, operating hardware, or glazing materials, and assumes no responsibility therefor.

Kawneer reserves the right to change configuration without prior notice when deemed necessary for product improvement.  
© 2011, Kawneer Company, Inc.

### System Solar Heat Gain Coefficient (SHGC) vs Percent of Vision Area

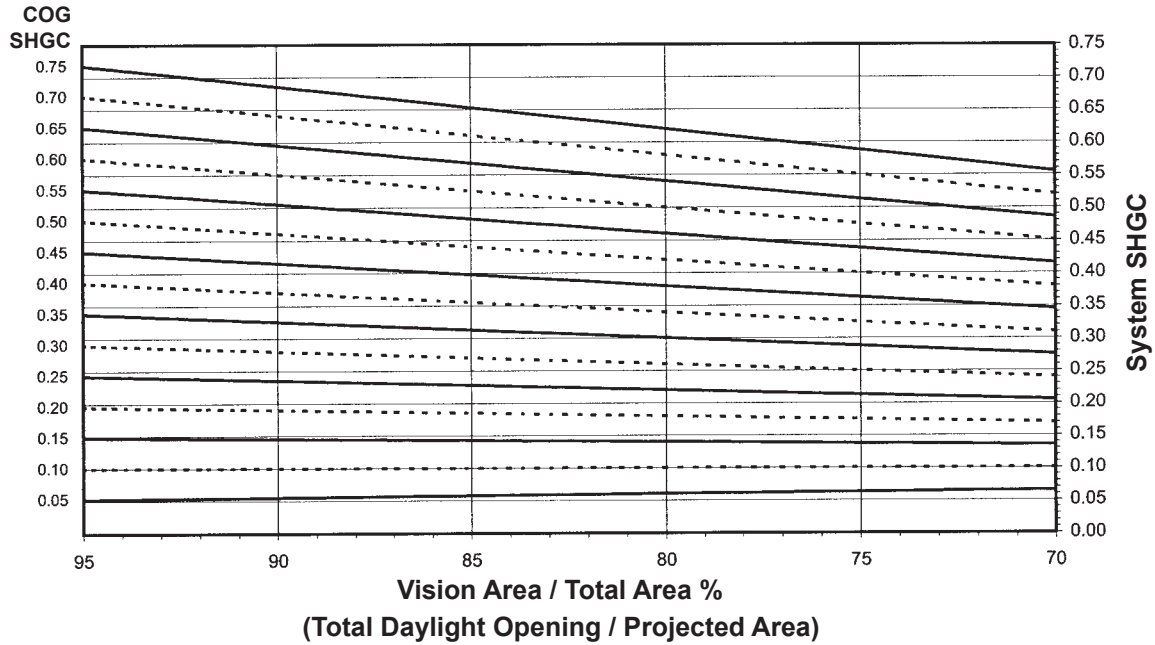

Charts are generated per AAMA 507

### Visible Transmittance (VT) vs Percent of Vision Area

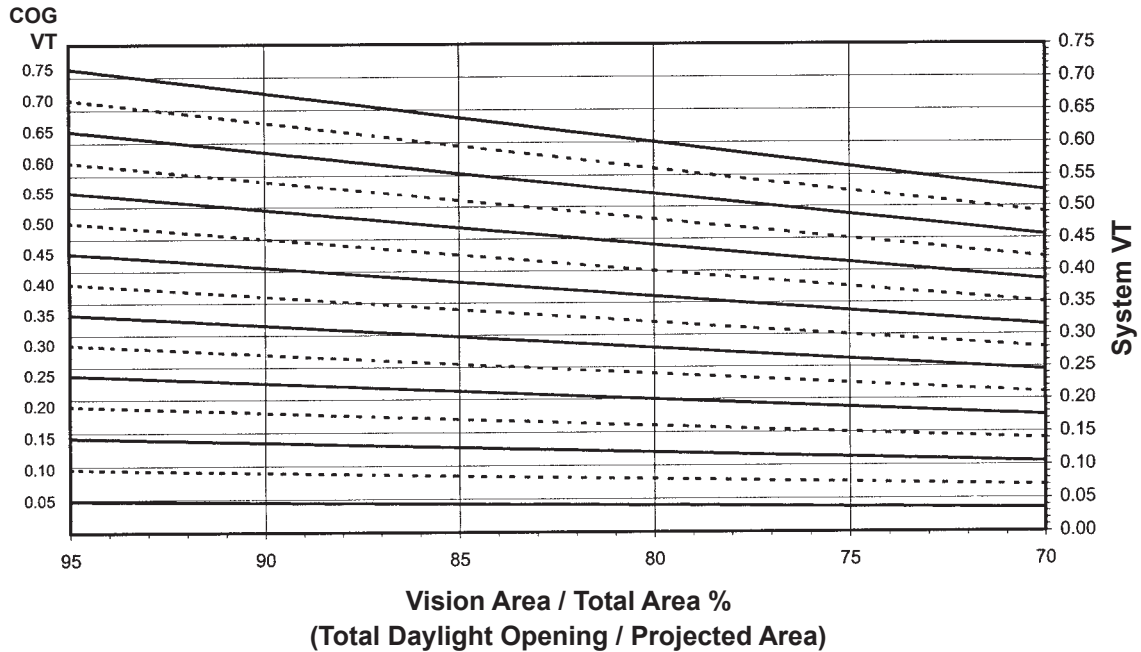

Laws and building and safety codes governing the design and use of Kawneer products, such as glazed entrance, window, and curtain wall products, vary widely. Kawneer does not control the selection of product configurations, operating hardware, or glazing materials, and assumes no responsibility therefor.

Kawneer reserves the right to change configuration without prior notice when deemed necessary for product improvement.  
© 2011, Kawneer Company, Inc.

**Thermal Transmittance <sup>1</sup> (BTU/hr • ft <sup>2</sup> • °F)**

Glass U-Factor <sup>3</sup>	Overall U-Factor <sup>4</sup>
0.48	0.61
0.46	0.59
0.44	0.58
0.42	0.56
0.40	0.54
0.38	0.53
0.36	0.51
0.34	0.49
0.32	0.48
0.30	0.46
0.28	0.44
0.26	0.43
0.24	0.41
0.22	0.39
0.20	0.38

**1" GLAZING WITH ALUMINUM PRESSURE PLATE**

**NOTE:** For glass values that are not listed, linear interpolation is permitted.

1. U-Factors are determined in accordance with NFRC 100.
2. SHGC and VT values are determined in accordance with NFRC 200.
3. Glass properties are based on center of glass values and are obtained from your glass supplier.
4. Overall U-Factor, SHGC, and VT Matrices are based on the standard NFRC specimen size of 2,000 mm wide by 2,000 mm high (78-3/4" by 78-3/4").

**SHGC Matrix <sup>2</sup>**

Glass SHGC <sup>3</sup>	Overall SHGC <sup>4</sup>
0.75	0.70
0.70	0.65
0.65	0.61
0.60	0.56
0.55	0.51
0.50	0.47
0.45	0.42
0.40	0.38
0.35	0.33
0.30	0.28
0.25	0.24
0.20	0.19
0.15	0.15
0.10	0.10
0.05	0.05

**Visible Transmittance <sup>2</sup>**

Glass VT <sup>3</sup>	Overall VT <sup>4</sup>
0.75	0.69
0.70	0.64
0.65	0.60
0.60	0.55
0.55	0.51
0.50	0.46
0.45	0.41
0.40	0.37
0.35	0.32
0.30	0.28
0.25	0.23
0.20	0.18
0.15	0.14
0.10	0.09
0.05	0.05

Laws and building and safety codes governing the design and use of Kawneer products, such as glazed entrance, window, and curtain wall products, vary widely. Kawneer does not control the selection of product configurations, operating hardware, or glazing materials, and assumes no responsibility therefor.

Kawneer reserves the right to change configuration without prior notice when deemed necessary for product improvement.  
© 2011, Kawneer Company, Inc.

Laws and building and safety codes governing the design and use of Kawneer products, such as glazed entrance, window, and curtain wall products, vary widely. Kawneer does not control the selection of product configurations, operating hardware, or glazing materials, and assumes no responsibility therefor.

Kawneer reserves the right to change configuration without prior notice when deemed necessary for product improvement.  
© 2011, Kawneer Company, Inc.